



Monoblok	Reeks	SHEEN EVO 2.0			Série	Monobloc
	Fabriekscode	WiSAN-YSE1 35.2 PRM			Fabriekscode	
Koelmiddel		R32				Réfrigérant
Erp (*)	Energielabel W35		A++		Label d'efficacité W35	Erp (*)
	ηs,h W35	%	160	%	ηs,h W35	
	SCOP W35		4,08		SCOP W35	
Verwarming (**)	Vermogen +7°C/35°C	kW	94,2	kW	Puissance +7°C/35°C	Chauffage (**)
	Opgeen. elektr. vermogen	kW	25,7	kW	Puissance él. absorbée	
	COP		3,67		COP	
	Vermogen +7°C/45°C	kW	91,2		Puissance +7°C/45°C	
	Opgeen. elektr. vermogen	kW	29,9	kW	Puissance él. absorbée	
	COP		3,05		COP	
Verwarming Max. vermogen	Vermogen -7°C/35°C	kW	67,1	kW	Puissance-10°C/35°C	Chauffage Puissance max.
	Vermogen -7°C/45°C	kW	62,0	kW	Puissance-10°C/45°C	
	Vermogen -15°C/35°C	kW	48,3	kW	Puissance-15°C/35°C	
	Vermogen -15°C/45°C	kW	45,0	kW	Puissance-15°C/45°C	
Koeling (**)	Vermogen 7-12 / 35°C	kW	86,2	kW	Puissance	Refroid. (**)
	Electr.verm.	kW	31,6	kW	Puiss. absorb.nom	
	EER / ESEER		2,73 / 3,91		EER / ESEER	
Monoblok	Geluidsdruk (1m)	dB(A)	65	dB(A)	Niv. son. press. (1m)	Monobloc
	Geluidsvermogen	dB	83	dB	Niv. son. puiss.	
	Geluidsdruk (1m) Super Silenced	dB(A)	59	dB(A)	Niv. son. press. (1m) Super Silenced	
	Geluidsvermogen Super Silenced	dB	77	dB	Niv. son. puiss. Super Silenced	
	Debiet	m³/h	40.500	m³/h	Débit	
	Werkingslim. verwarmen wateruitrede	°C	25° - 55°	°C	Plage de fonct. chauff. Sortie d'eau	
	Werkingslim. verwarmen buitentemp.	°C	-15° - 44°	°C	Plage de fonct. chauff. Temp. Ext.	
	Werkingslim. Koelen wateruitrede	°C	0° - 20°	°C	Plage de fonct. refroid. Sortie d'eau.	
	Werkingslim. Koelen buitentemp.	°C	-10° - 48°	°C	Plage de fonct. refroid.Temp. Ext.	
	Hoogte-breedte-lengte	mm	1510-1100-3330	mm	Hauteur/largeur/profond.	
Gewicht	kg	830	kg	Poids		
Elektr. Install.	Voeding	V	400V/3F+N	V	Alimentation	Install. Électr.
	Stroom max.	A	59,0	A	Amp. max	
Controller	Communicatie		Modbus RTU		Communication	Régulateur
	Smart grid functie		Neer/Non		Smart grid fonction	
	Uitgebreide aansturing (REMAU)		Neer/Non		Options de contrôle étendues (REMAU)	
	Cascade management		Ja/Oui		Cascade management	
	Hybride controle		Ja/Oui		Contrôle Hybride	
Tech.install.	Waterdebiet (Koeling 7/12°C)	l/s	4,10	l/s	Débit d'eau (Refroidissement 7/12°C)	Install. Techn.
	Drukval over wisselaar (Koeling 7/12°C)	kPa	46,2	kPa	Perte de press. échangeur (7/12°C)	
	Compressor		Scroll Inverter		Compresseur	
	Aantal compressors		2		Quantité compresseurs	
	Type wisselaar		Platen/Plaque		Type échangeur	
	Min. primaire waterinhoud heat/cool	l	650 / 200	l	Contenu Min. d'eau prim. heat/cool	
Maximale waterdruk	bar	10	bar	Pression maximum d'eau		
Koelmiddel (***)	Koudemiddel		R32		Réfrigérant	Réfrigérant (***)
	GWP-waarde		675		GWP-valeur	
	Standaardvulling	kg	17,5	kg	Charge standard	
	CO <sub>2</sub> eq. Standaardvulling	ton	11,8	ton	CO <sub>2</sub> eq. Charge standard	
	Bijvulling	g/m	-	g/m	Charge supplémentaire	
	CO <sub>2</sub> eq. Bijvulling	ton/m	-	ton/m	CO <sub>2</sub> -eq Charge supplémentaire	
	Bevat gefluoreerde broeikasgassen		Ja/Oui		Contient des gaz à effet de serre fluorés	
	Hermetisch gesloten koelcircuit		Ja/Oui		hermétiquement scellé	

(\*) EU 811/2013 (≤70kW en EU 813/2013 (≤400kW)

(\*) EU 811/2013 (≤70kW et EU 813/2013 (≤400kW)

(\*\*) EN 14511:2022

(\*\*) EN 14511:2022

(\*\*\*) Europese verordening nr 517/2014 betreffende gefluoreerde broeikasgassen

(\*\*\*) Le décret Européen n° 517/2014 sur le gaz à effet de serre fluorés

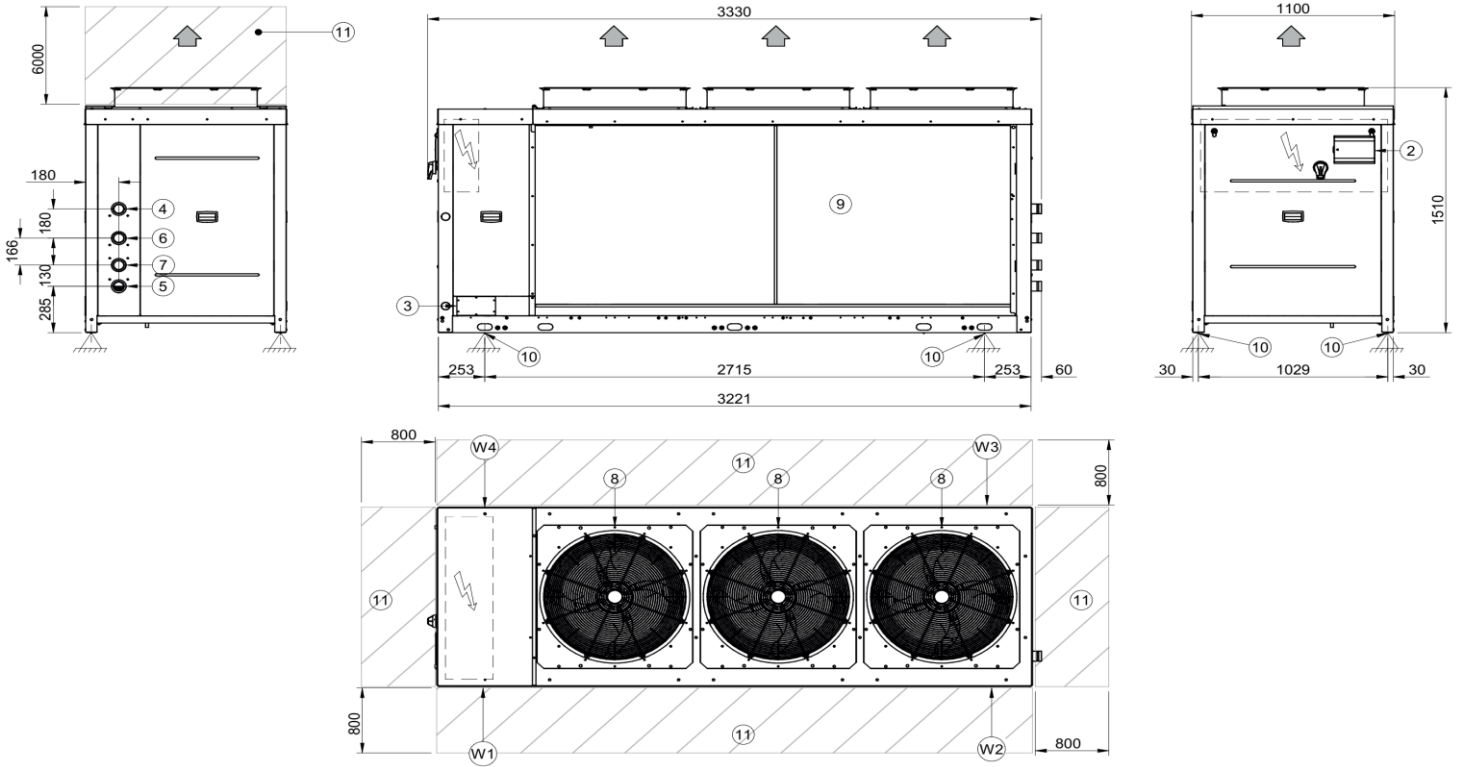

1. Compressor compartment
2. Electrical panel
3. Power input
4. Inlet water connection Victaulic 2"
5. Outlet water connection Victaulic 2"
6. Inlet DHW connection Victaulic 2"
7. Outlet DHW connection Victaulic 2"
8. Fan
9. External exchanger
10. Unit fixing holes
11. Functional clearances

Length	mm	3330
Depth	mm	1100
Height	mm	1510
W1 Support point	kg	280
W2 Support point	kg	135
W3 Support point	kg	135
W4 Support point	kg	280
Operation weight	kg	830
Operating weight	kg	830

Cooling

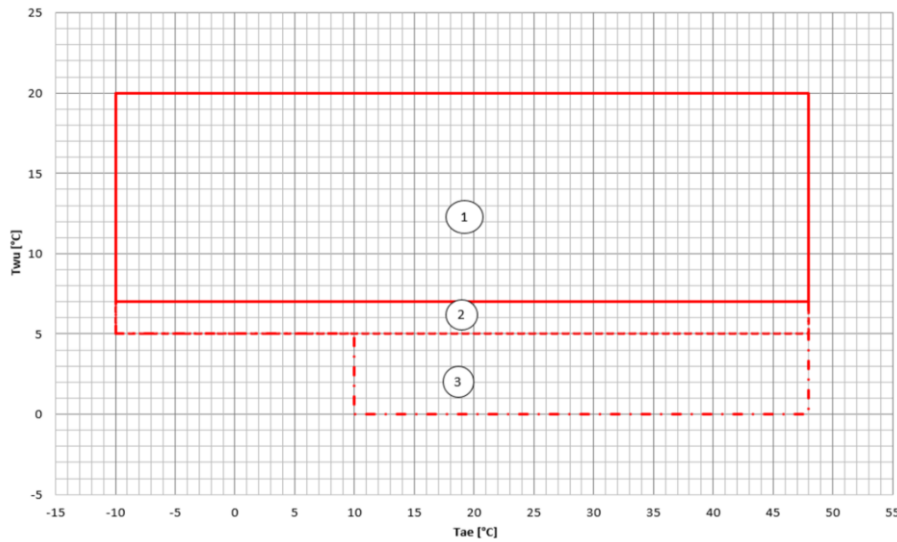

T<sub>wu</sub> [°C] = Leaving exchanger water temperature

T<sub>ae</sub> [°C] = External exchanger inlet air temperature

1. Normal operating range
2. Low water temperature operating range in which the use of only water as the operating fluid is allowed.
3. Low water temperature operating range where the use of ethylene or propylene glycol is mandatory, depending on the temperature of the leaving fluid

Heating

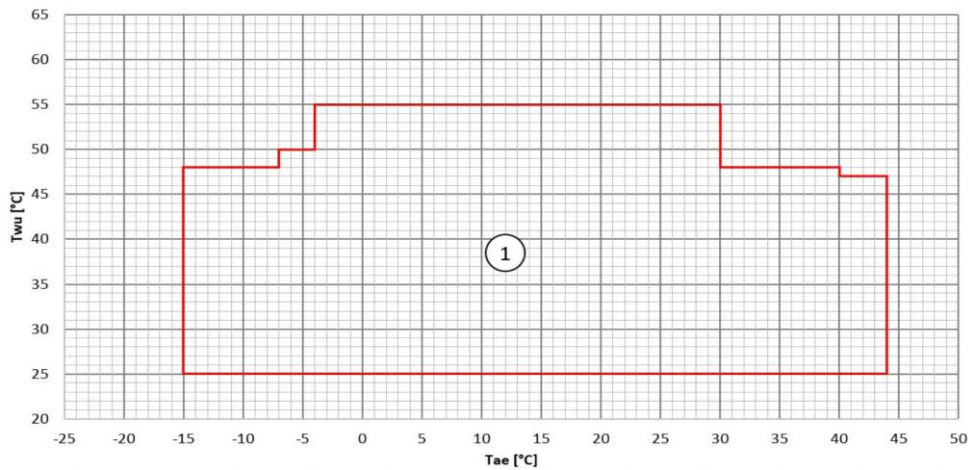

T<sub>wu</sub> [°C] = Leaving exchanger water temperature

T<sub>ae</sub> [°C] = External exchanger inlet air temperature

1. Normal operating range.

**Head - Size 30.2 - 35.2 - 40.2**

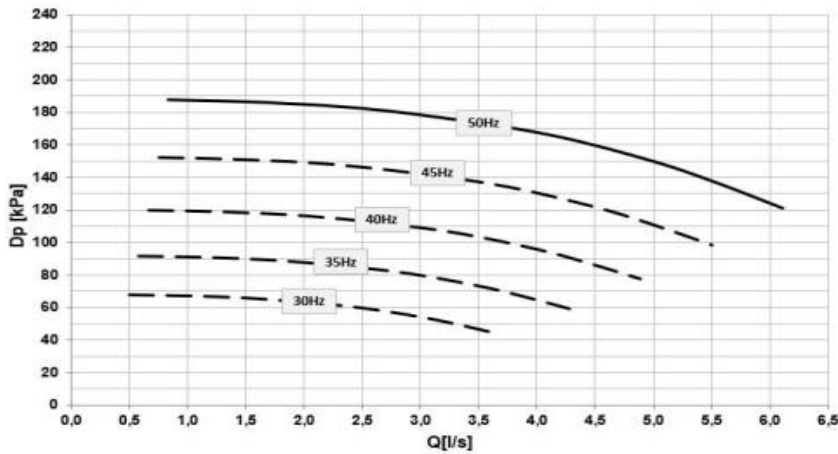

DP = Pressure head [kPa]  
Q = Water flow rate [l/s]

⚠ Caution: to obtain the available pressure values, you need to subtract the following from the head values represented in these diagrams:

- User side exchanger pressure drops
- IFVX accessory –Steel mesh filter on the water side (where applicable)

**Power input - Size 30.2 - 35.2 - 40.2**

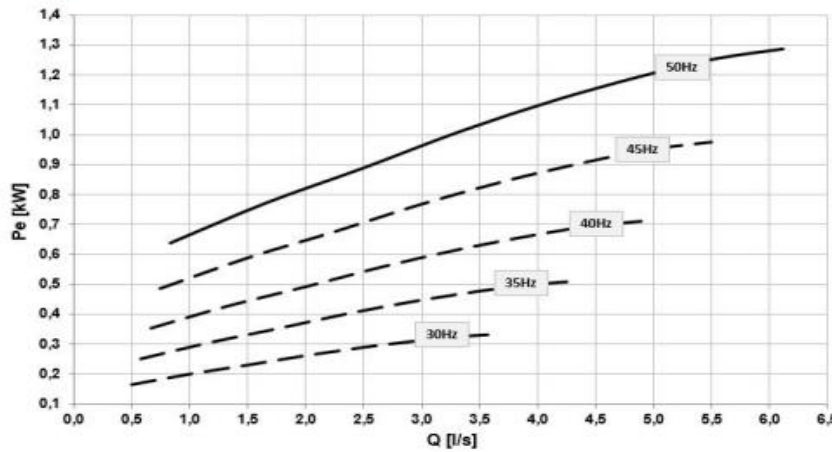

Pe = Electric power consumption [kW]  
Q = Water flow rate [l/s]

**Electrical data**

SIZE		30.2	35.2	40.2
F.L.A.	A	4,6	4,6	4,6
F.L.I.	kW	2,2	2,2	2,2

(°) Enkel indien de circulatiepomp HYGU1V (optie) mee is besteld.

(°) Seulement la pompe de circulation HYGU1V (option) est commandé.

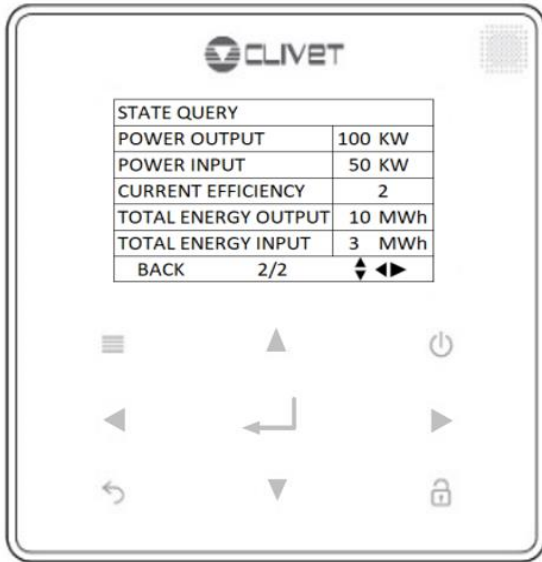

- To lockout / unlock
- To modify current setpoint
- To open the various menus from the HOME screen
- To move the cursor, change the selection or change the set value  
The parameter can be quickly changed with a long press
- To confirm an operation
- To set the ON / OFF function
- To return to the previous level  
Press to exit the current page and return to the previous page  
Long press to return straight to the home screen

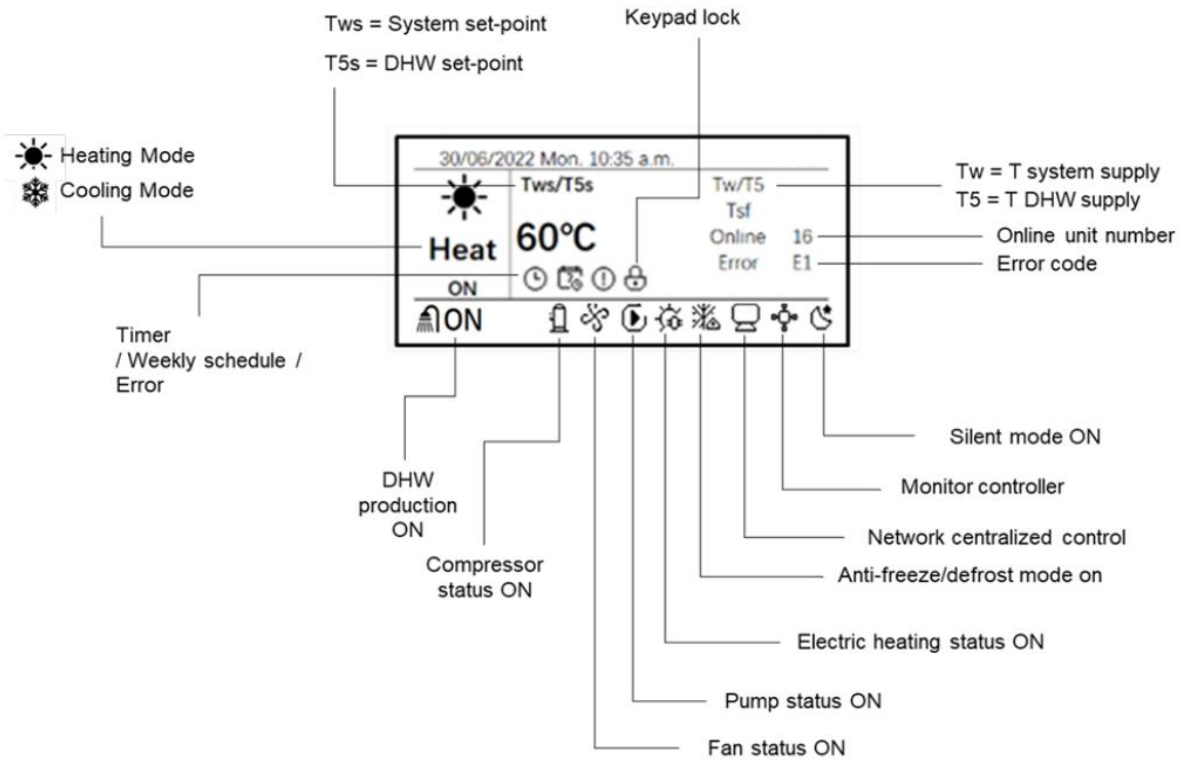

### Modularity

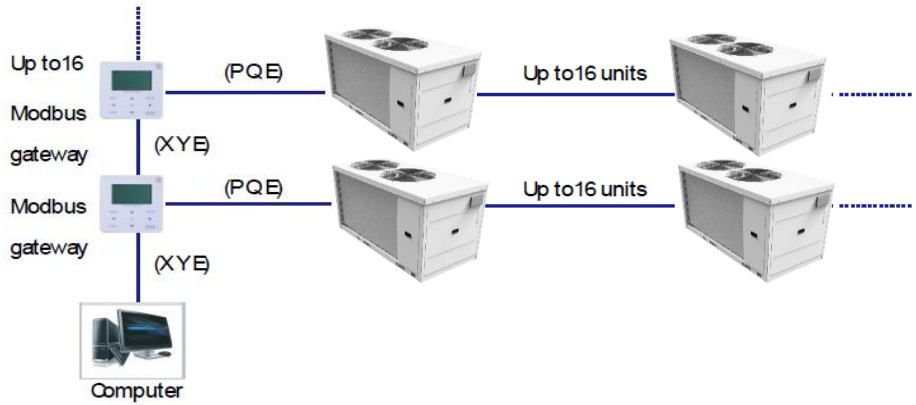

### Duty Cycling

Duty cycling **equalizes** the running time of the outdoor units in a multiple-unit system, significantly extending compressor lifespan.

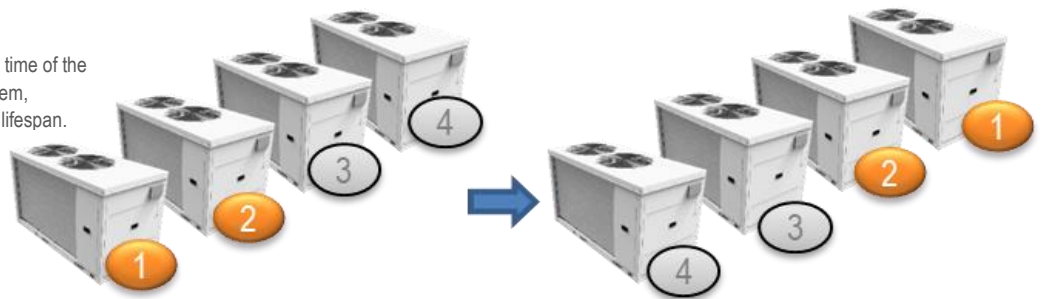

### Back-up

In a multi-unit system, if one module fails, the other modules provide backup so that the system can continue operating.

