



Monoblok	Reeks Fabriekscode	SHEEN EVO 2.0 WiSAN-YSE1 12.1 PRM			Série Fabriekscode	Monobloc
Koelmiddel		R32				Réfrigérant
Erp (*)	Energielabel W35		A++		Label d'efficacité W35	Erp (*)
	ηs,h W35	%	166	%	ηs,h W35	
	SCOP W35		4,23		SCOP W35	
Verwarming (**)	Vermogen +7°C/35°C	kW	32,3	kW	Puissance +7°C/35°C	Chauffage (**)
	Opgeen. elektr. vermogen	kW	8,1	kW	Puissance él. absorbée	
	COP		4,01		COP	
	Vermogen +7°C/45°C	kW	29,8		Puissance +7°C/45°C	
	Opgeen. elektr. vermogen	kW	9,3	kW	Puissance él. absorbée	
	COP		3,20		COP	
Verwarming Max. vermogen	Vermogen -7°C/35°C	kW	21,3	kW	Puissance-10°C/35°C	Chauffage Puissance max.
	Vermogen -7°C/45°C	kW	18,7	kW	Puissance-10°C/45°C	
	Vermogen -15°C/35°C	kW	11,4	kW	Puissance-15°C/35°C	
	Vermogen -15°C/45°C	kW	-	kW	Puissance-15°C/45°C	
Koeling (**)	Vermogen 7-12 / 35°C	kW	27,6	kW	Puissance	Refruid. (**)
	Electr.verm.	kW	10,0	kW	Puiss. absorb.nom	
	EER / ESEER		2,75 / 4,40		EER / ESEER	
Monoblok	Geluidsdruk (1m)	dB(A)	60	dB(A)	Niv. son. press. (1m)	Monoblok
	Geluidsvermogen	dB	76	dB	Niv. son. puiss.	
	Geluidsdruk (1m) Super Silenced	dB(A)	57	dB(A)	Niv. son. press. (1m) Super Silenced	
	Geluidsvermogen Super Silenced	dB	73	dB	Niv. son. puiss. Super Silenced	
	Debiet	m³/h	13.500	m³/h	Débit	
	Werkingslim. verwarmen wateruitrede	°C	25° - 55°	°C	Plage de fonct. chauff. Sortie d'eau	
	Werkingslim. verwarmen buitentemp.	°C	-15° - 44°	°C	Plage de fonct. chauff. Temp. Ext.	
	Werkingslim. Koelen wateruitrede	°C	0° - 20°	°C	Plage de fonct. refroid. Sortie d'eau.	
	Werkingslim. Koelen buitentemp.	°C	-10° - 48°	°C	Plage de fonct. refroid.Temp. Ext.	
Hoogte-breedte-lengte	mm	1340-1005-1960	mm	Hauteur/largeur/profond.		
Gewicht	kg	333	kg	Poids		
Elektr. Install.	Voeding	V	400V/3F+N	V	Alimentation	Install. Électr.
	Stroom max.	A	19,0	A	Amp. max	
Controller	Communicatie		Modbus RTU		Communication	Régulateur
	Smart grid functie		Nee/Non		Smart grid fonction	
	Uitgebreide aansturing (REMAU)		Nee/Non		Options de contrôle étendues (REMAU)	
	Cascade management		Ja/Oui		Cascade management	
	Hybride controle		Ja/Oui		Contrôle Hybride	
Tech.install.	Waterdebiet (Koeling 7/12°C)	l/s	1,32	l/s	Débit d'eau (Refroidissement 7/12°C)	Install. Techn.
	Drukval over wisselaar (Koeling 7/12°C)	kPa	38,7	kPa	Perte de press. échangeur (7/12°C)	
	Compressor		Rotary Inverter		Compresseur	
	Aantal compressors		1		Quantité compresseurs	
	Type wisselaar		Platen/Plaque		Type échangeur	
	Min. primaire waterinhoud heat/cool	l	200 / 80	l	Contenu Min. d'eau prim. heat/cool	
Maximale waterdruk	bar	10	bar	Pression maximum d'eau		
Koelmiddel (***)	Koudemiddel		R32		Réfrigérant	Réfrigérant (***)
	GWP-waarde		675		GWP-valeur	
	Standaardvulling	kg	7,9	kg	Charge standard	
	CO ₂ eq. Standaardvulling	ton	5,3	ton	CO ₂ eq. Charge standard	
	Bijvulling	g/m	-	g/m	Charge supplémentaire	
	CO ₂ eq. Bijvulling	ton/m	-	ton/m	CO ₂ -eq Charge supplémentaire	
	Bevat gefluoreerde broeikasgassen		Ja/Oui		Contient des gaz à effet de serre fluorés	
Hermetisch gesloten koelcircuit		Ja/Oui		hermétiquement scellé		

(*) EU 811/2013 (≤70kW en EU 813/2013 (≤400kW)

(*) EU 811/2013 (≤70kW et EU 813/2013 (≤400kW)

(**) EN 14511:2022

(**) EN 14511:2022

(***) Europese verordening nr 517/2014 betreffende gefluoreerde broeikasgassen

(***) Le décret Européen n° 517/2014 sur le gaz à effet de serre fluorés

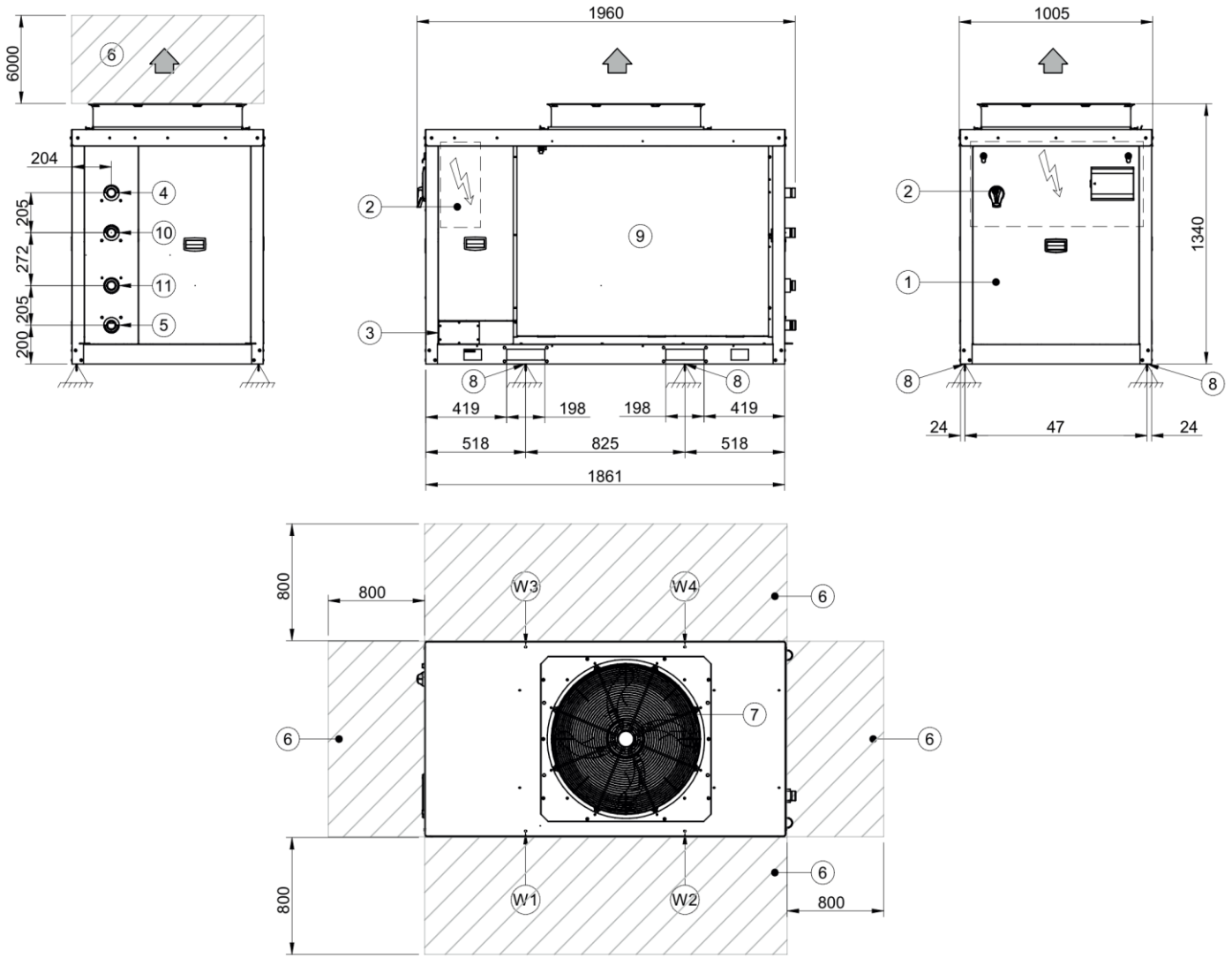

1. Compressor compartment
2. Electrical panel
3. Power input
4. Inlet water connection Victaulic 1" 1/2
5. Outlet water connection Victaulic 1" 1/2
6. Functional clearances
7. Fan
8. Unit fixing holes
9. External exchanger
10. DHW inlet (optional) Victaulic 1 1/2"
11. DHW outlet (optional) Victaulic 1 1/2"

Length	mm	1960
Depth	mm	1005
Height	mm	1340
W1 Support point	kg	90
W2 Support point	kg	71
W3 Support point	kg	91
W4 Support point	kg	71
Operation weight	kg	323
Operating weight	kg	333

Cooling

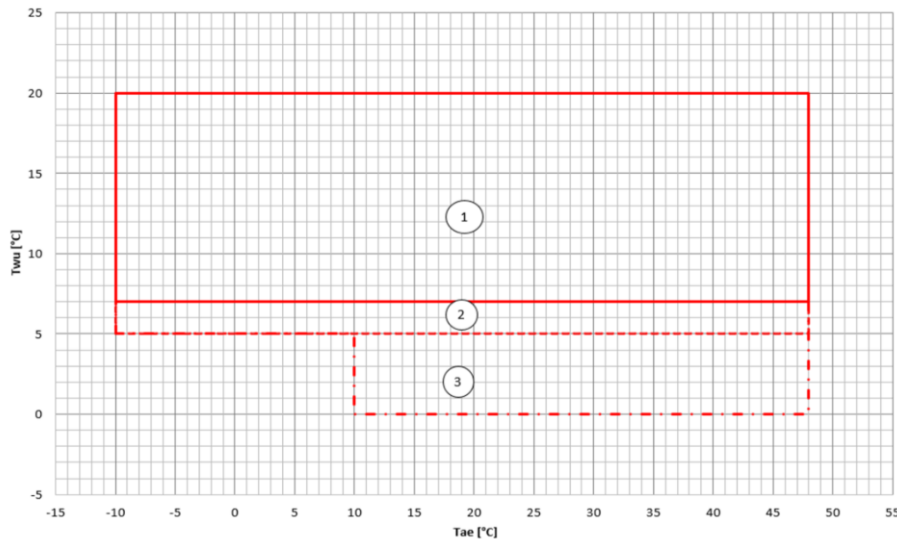

T_{wu} [°C] = Leaving exchanger water temperature
 T_{a,e} [°C] = External exchanger inlet air temperature

1. Normal operating range
2. Low water temperature operating range in which the use of only water as the operating fluid is allowed.
3. Low water temperature operating range where the use of ethylene or propylene glycol is mandatory, depending on the temperature of the leaving fluid

Heating

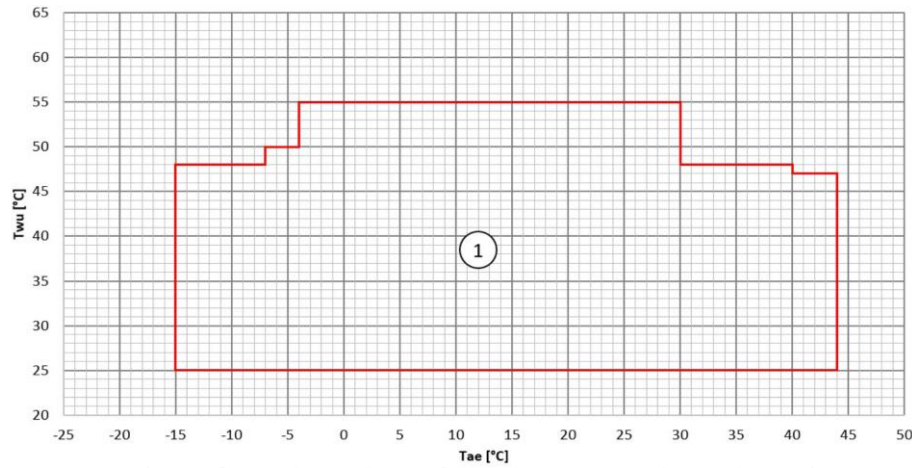

T_{wu} [°C] = Leaving exchanger water temperature
 T_{a,e} [°C] = External exchanger inlet air temperature

1. Normal operating range.

Head - Size 10.1 - 12.1 - 14.1

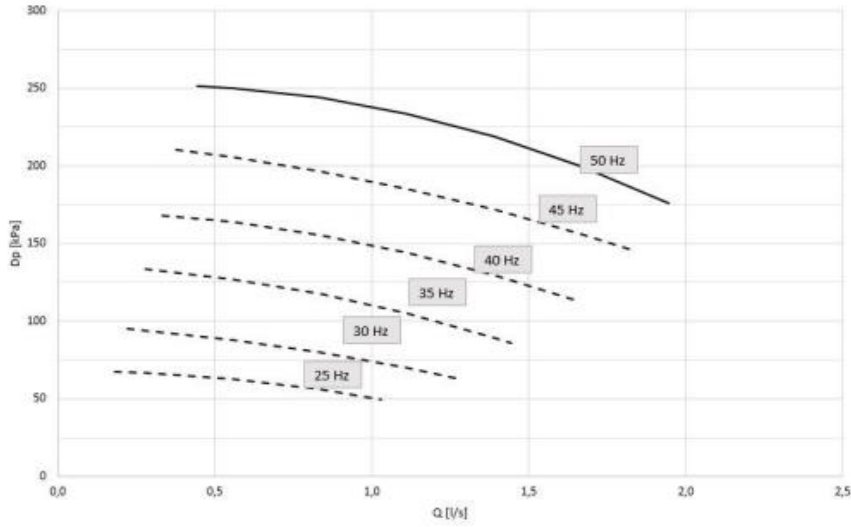

DP = Pressure head [kPa]
Q = Water flow rate [l/s]

⚠ Caution: to obtain the available pressure values, you need to subtract the following from the head values represented in these diagrams:

- User side exchanger pressure drops
- IFVX accessory – Steel mesh filter on the water side (where applicable)

Power input - Size 10.1 - 12.1 - 14.1

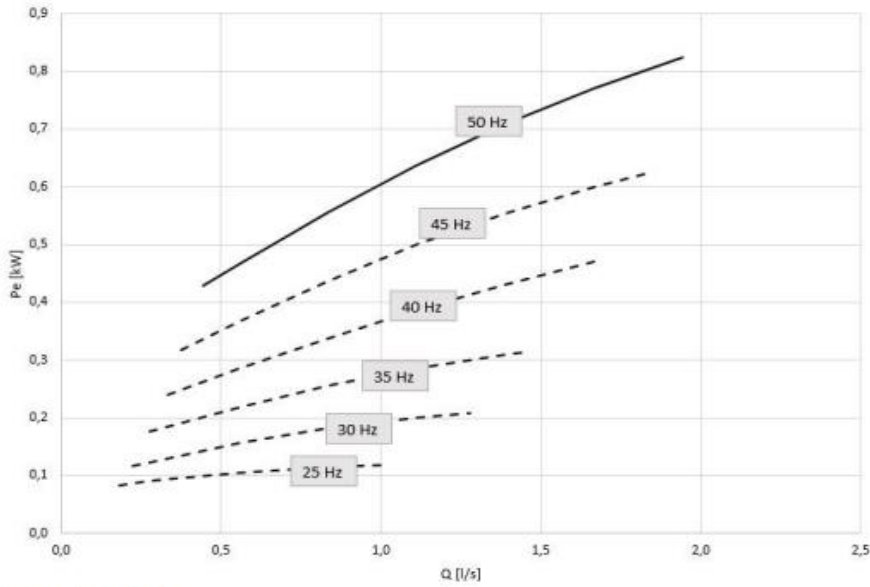

Pe = Electric power consumption [kW]
Q = Water flow rate [l/s]

Electrical data

SIZE		10.1	12.1	14.1
F.L.A.	A	2,2	2,2	2,2
F.L.I.	kW	1,1	1,1	1,1

(°) Enkel indien de circulatiepomp HYGU1V (optie) mee is besteld.

(°) Seulement la pompe de circulation HYGU1V (option) est commandé.

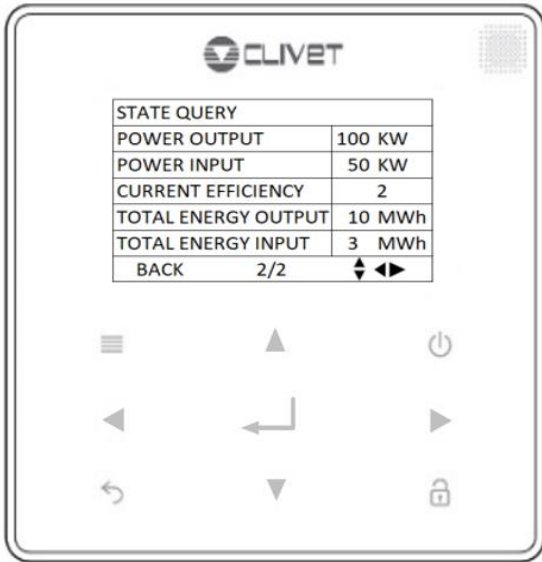

- To lockout / unlock
- To modify current setpoint
- To open the various menus from the HOME screen
- To move the cursor, change the selection or change the set value
The parameter can be quickly changed with a long press
- To confirm an operation
- To set the ON / OFF function
- To return to the previous level
Press to exit the current page and return to the previous page
Long press to return straight to the home screen

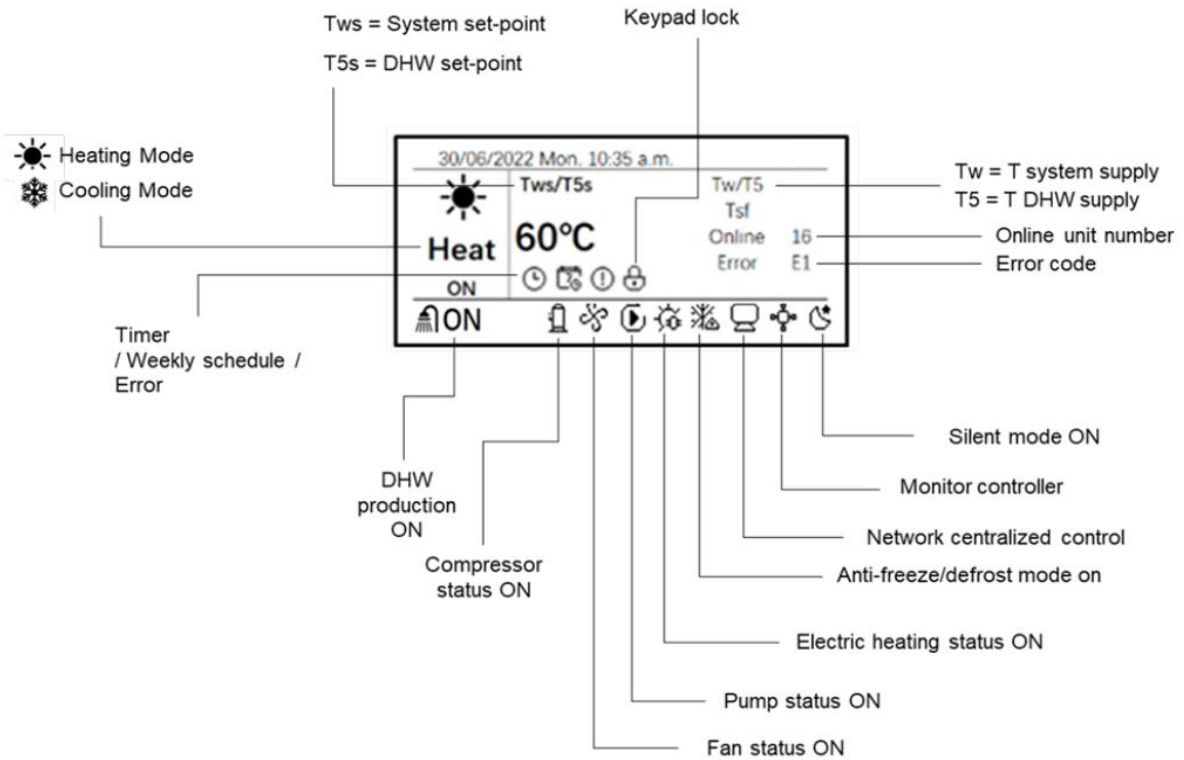

Modularity

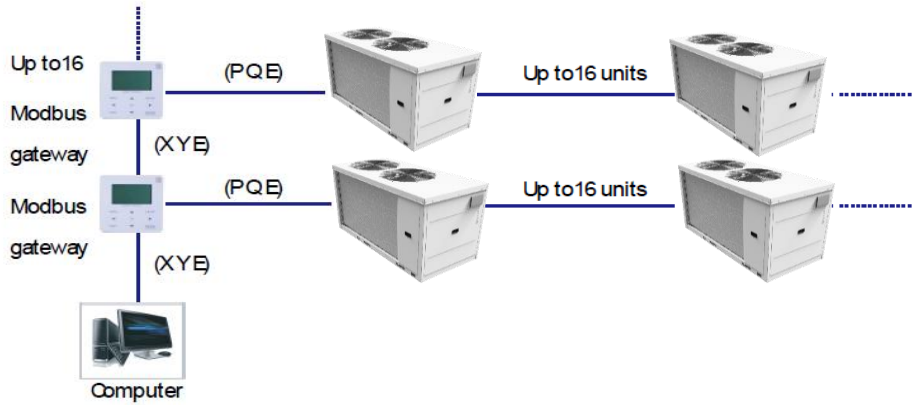

Duty Cycling

Duty cycling **equalizes** the running time of the outdoor units in a multiple-unit system, significantly extending compressor lifespan.

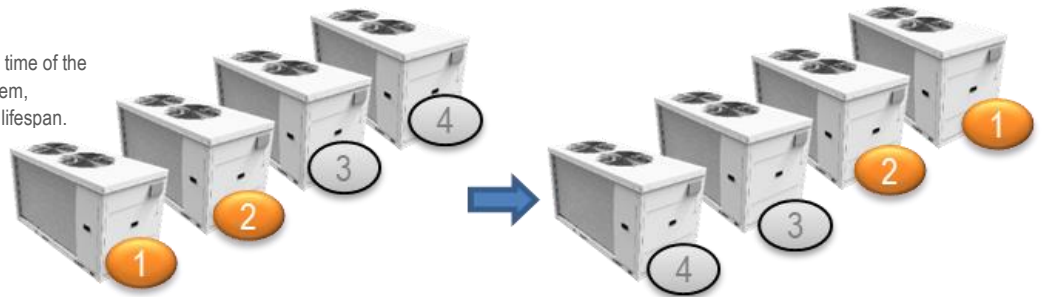

Back-up

In a multi-unit system, if one module fails, the other modules provide backup so that the system can continue operating.

