

INTERFACE SPECIFICATION

MODBUS CONVERTOR UTY-VMSX

PART NO. 9708438047-03

FUJITSU GENERAL LIMITED

Contents

1 SYSTEM OUTLINE	1
2 DIMENSION	2
3 SPECIFICATION	3
3-1. Operating Environment	3
3-2. Transmission (Hardware)	3
3-3. Function	4
4 MODBUS SYSTEM OUTLINE	5
5 COMMUNICATION SPECIFICATIONS	6
6 SUPPORTED FUNCTION LIST	6
7 EXCEPTION RESPONSE	6
8 OBJECT COMPOSITION	7

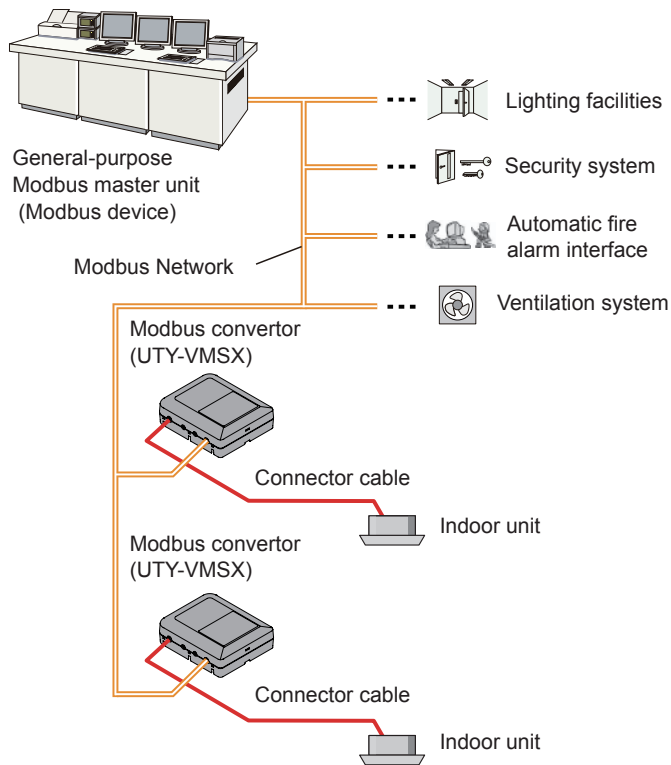

(1) What is the Modbus Converter ?

The convertor for connecting our Indoor Unit to the system built by Modbus, an open network, to manage the Indoor Unit.

(2) Maximum Connectable number per 1 Modbus Converter.

Indoor Unit	1
-------------	---

(3) Maximum connectable number per 1 BMS.

Modbus Converter without repeater	31
Modbus Converter with repeater	247

The Modbus convertor is comprised of a body and cover.

Unit : mm (in)

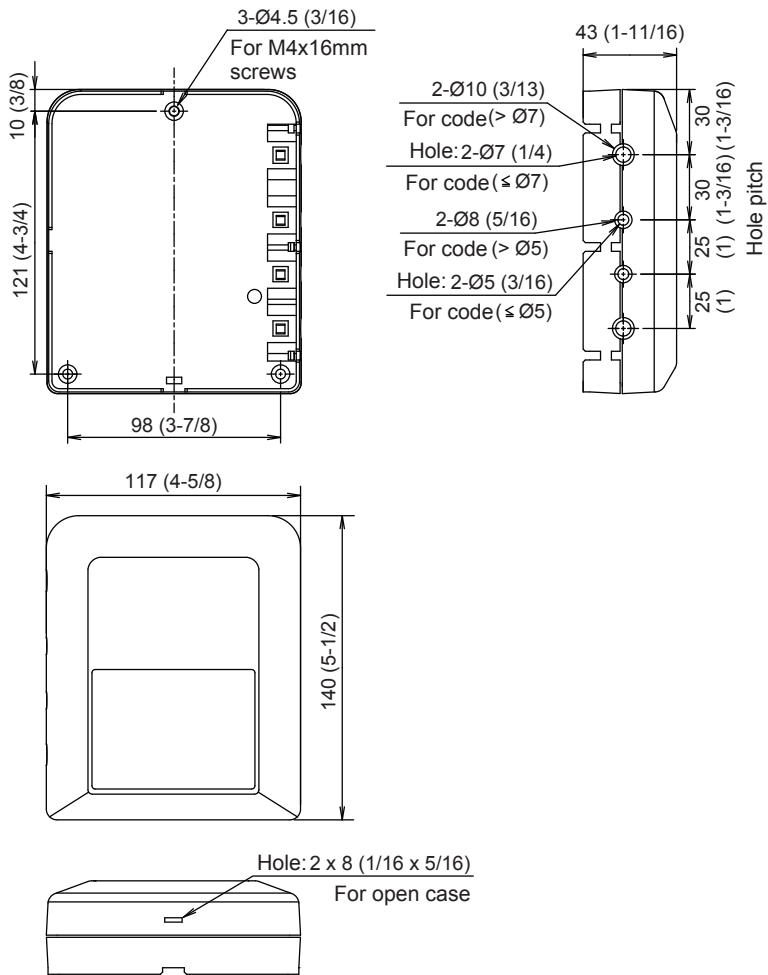

3-1. Operating Environment

Power consumption (W)		1.2
Temperature °C (°F)	Operating	0–46 (32–114)
	Packaged	-10–60 (14–140)
Humidity (%)	Packaged	0–95 (RH); No condensation
Dimensions H × W × D mm (in)		43 x 117 x 140 (1-11/16 x 4-5/8 x 5-1/2)
Weight g (oz)		200 (7)

3-2. Transmission (Hardware)

Use	Size		Wire type	Remarks
MODBUS cable	Maximum	1.25 mm ² (16AWG)	AWG16-26 3Wire+ Sheathed PVC cable	
	Minimum	0.128 mm ² (26AWG)		

3-3. Function

Item* ¹	Control* ²	Monitor Information* ³	Convertor
	Indoor Unit	Indoor Unit	
ON/OFF command	●	●	
Operation mode setting	●	●	
Temperature setting	●	●	
Airflow mode setting	●	●	
Set point temperature limit setting	●	●	
Thermostat off setting	●	●	
Centrally control (Filter reset)	●	●	
Centrally control (All mode)	●	●	
Centrally control (Timer mode)	●	●	
Centrally control (Set temperature mode)	●	●	
Centrally control (ON/OFF mode)	●	●	
Centrally control (ON mode)	●	●	
Centrally control (Operation mode)	●	●	
Filter sign reset	●	●	
Antifreeze setting	●	●	
Energy save mode setting	●	●	
Vertical/horizontal airflow direction louver setting	●	●	
Room temperature		●	
Error code status		●	●
Indoor unit status		●	
Modbus communication setting information			●
Model name			●
Software version			●
Demand status		●	
Human detection auto save	●	●	
Human detection auto off	●	●	

*¹ Refer to the product manuals for each function.

*² Modbus network → Indoor Unit

*³ Indoor Unit → Modbus network

This manual describes Modbus protocol interface specifications of Modbus Convertor. Modbus Convertor is equipped with the Modbus Slave function. Specifications that are not detailed in this manual conform to the following MODBUS specifications.

- Modbus Application Protocol Specification V1.1b3
- Modbus over Serial Line Specification and Implementation Guide V1.02

<http://www.modbus.org/>

This interface specification specifies the operation of Modbus that works on the RS485 serial line, where a slave device sends a response to a request from the master device. Multiple slave devices are connected to the RS485 bus. Modbus uses the Modbus RTU mode with the frame format shown below.

Signal composition

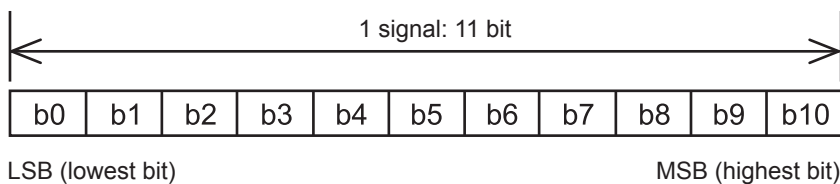

Bit name	Number of bit	Content
b0	1 bit	Start bit
b1 to b8	8 bit	Data bit
b9	1 bit	Parity bit or stop bit (When no parity)
b10	1 bit	Stop bit

Transmission frame composition

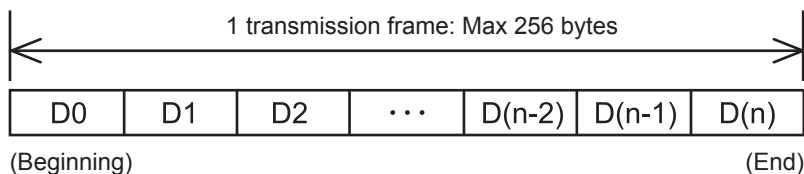

Octet name	Number of bit	Content
D0	1 byte	Transmission destination / transmission source slave address
D1	1 byte	Function code
D2 to D(n-2)	MAX 252 byte	Frame data
D(n-1) to D(n)	2 byte	Error check

5

COMMUNICATION SPECIFICATIONS

Transfer mode	RTU mode
Communication method	Half-duplex operation, Master/slave method
Communication speed	9600bps / 19200bps
Synchronous system	Asynchronous communication method
Data bit	8 bit
Parity	even/odd/none
Stop bit	2 bit (no parity) / 1 bit
Network	3 wire RS485
Maximum cable length	1000 (m) (3280 (ft))

6

SUPPORTED FUNCTION LIST

Function code	Function name	Modbus register address* ¹	Max number of reading / writing address
0x03	Read holding register	40001 to 49999	125 addresses
0x04* ²	Read Input register	30001 to 39999	125 addresses
0x06	Write single holding register	40001 to 49999	1 address
0x10	Write multiple holding registers	40001 to 49999	123 addresses

*¹ Modbus register address put in transmission frame data is calculated by subtracting 1 from the residue obtained by dividing the described Modbus register address by 10000.

Example) Modbus register address 35555 is put in frame data as 5554
(Subtract 1 from the residue obtained by dividing 35555 by 10000.)

*² In the following cases, the response value is "0" for the request of "Function code: 0x04".

- When the indoor unit has no function
- When the monitor value cannot be returned by indoor unit status

7

EXCEPTION RESPONSE

Exception code	Exception name	Exception content
0x01	Invalid function code	Unsupported function code destination
0x02	Invalid Modbus address	Non-existent Modbus register address destination

Unit No	Modbus register address	Function	Functional detail	Value
Modbus Converter	30001	Communication speed information	Modbus communication speed set to Modbus Converter	0: 9600bps 1: 19200bps
	30002	Slave address information	Modbus slave address information set to Modbus Converter	bit0 to bit7: 1 to 247
	30003	Model name information 1	Model name information 1 of Modbus Converter	bit0 to bit7: (1) bit8 to bit15: (2) (UTY-(1) (2) (3) (4))
	30004 to 30006	(Reserved Modbus register address)		
	30007	Software version information	Software version information of Modbus Converter	bit0 to bit3: (1) bit4 to bit7: (2) bit8 to bit11: (3) bit12 to bit15: (4) (Version: E□□□V (1) (2)P (3) (4) L△△-☆)
	30008	(Reserved Modbus register address)		
	30009	Error monitoring	Error monitoring of Modbus Converter	bit0: Error/No error (0: No error, 1: Error) bit8 to bit11: Error code subsection bit12 to bit15: Error code section
	30010 to 30050	(Reserved Modbus register address)		

Unit No	Modbus register address	Function	Functional detail	Value
Indoor Unit	30051 to 30053	(Reserved Modbus register address)		
	30054	Operation mode status	Operation mode status monitoring	1: Auto 2: Cool 3: Dry 4: Heat 5: Fan
	30055	Operation ON/OFF status	Operation ON/OFF status monitoring	1: Stop 2: Operation
	30056	Set temperature status	Set temperature status monitoring	bit0 to bit8: Set value (Temperature = Set value / 4) Example) 0°C = 0, 20°C = 80, 30°C =120 by every 0.25°C
	30057	Airflow status	Airflow status monitoring	1:Auto 2:Quiet 3:Low 4:Med 5:High 6:Med-Low 7:Med-High
	30058	Indoor temperature status	Indoor temperature monitoring	bit0 to bit8: Set value (Temperature = Set value / 4) Example) 0°C = 0, 20°C = 80, 30°C =120 by every 0.25°C
	30059	Error monitoring	Error status monitoring	bit0: Error/No error (0: No error, 1: Error) bit8 to bit11: Error code subsection bit12 to bit15: Error code section
	30060	Vertical air direction position status	Vertical air direction position status monitoring	1: Swing 2: Position 1 3: Position 2 4: Position 3 5: Position 4
	30061	Horizontal air direction position status	Horizontal air direction position status monitoring	1: Swing 2: Position 1 3: Position 2 4: Position 3 5: Position 4 6: Position 5
	30062	Remote controller operation prohibition setting status	Remote controller operation prohibition setting status monitoring	bit0: ALL operation settings (0: Not inhibit, 1: Valid) bit1: Timer setting (0: Not inhibit, 1: Valid) bit2: Room temperature setting (0: Not inhibit, 1: Valid) bit3: Operation mode setting (0: Not inhibit, 1: Valid) bit4: Start/Stop operation setting (0: Not inhibit, 1: Valid) bit5: Start operation setting (0: Not inhibit, 1: Valid) bit6: Filter Reset operation (0: Not inhibit, 1: Valid)
	30063	Filter sign status	Filter sign monitoring	0: No sign 1: Filter sign
	30064	Economy mode operation status	Economy mode operation status monitoring	1: Normal operation 2: Save operation

Unit No	Modbus register address	Function	Functional detail	Value
Indoor Unit	30065	Antifreeze operation status	Antifreeze operation status monitoring	1: Normal operation 2: Antifreeze operation
	30066	Temperature upper and lower limit setting status (Cool/Dry)	Temperature upper and lower limit setting status monitoring of Cool/Dry operation mode	0: Invalid bit0 to bit7: Set value (Upper limit) bit8 to bit15: Set value (Lower limit) (Temperature = Set value / 4) Example) 0.5°C = 2, 20°C = 80, 30°C =120 by every 0.5°C
	30067	Temperature upper and lower limit setting status (Heat)	Temperature upper and lower limit setting status of Heat operation mode	0: Invalid bit0 to bit7: Set value (Upper limit) bit8 to bit15: Set value (Lower limit) (Temperature = Set value / 4) Example) 0.5°C = 2, 20°C = 80, 30°C =120 by every 0.5°C
	30068	Temperature upper and lower limit setting status (Auto)	Temperature upper and lower limit setting status of Auto operation mode	0: Invalid bit0 to bit7: Set value (Upper limit) bit8 to bit15: Set value (Lower limit) (Temperature = Set value / 4) Example) 0.5°C = 2, 20°C = 80, 30°C =120 by every 0.5°C
	30069	Indoor unit status	Indoor unit special status monitoring	bit0: Normal status (0: Special status, 1: Normal status) bit1: Defrosting (0: No defrosting status, 1: Defrosting status) bit2: Oil recovery (0: No oil recovery status, 1: Oil recovery status) bit3: Pump down (0: No pump down status, 1: Pump down status)
	30070	External thermo-off status	External thermo-off status monitoring	1: Release 2: Thermo-off
	30071	Demand monitoring	Demand control status monitoring	1: No operation 2: DRM 1 3: DRM 2 4: DRM 3
	30072	Human detection auto save status	Human detection auto save status monitoring	0: No operation 1: Operation
	30073	Human detection auto save time status	Human detection auto save set time status monitoring	bit0 to bit10: Set value (Time (minute) = Set value) Example) 60 minutes = 60, 120 minutes = 120 by every 15 minutes
	30074	Human detection auto off status	Human detection auto off status monitoring	0: No operation 1: Operation
	30075	Human detection auto off time status	Human detection auto off set time status monitoring	bit0 to bit10: Set value (Time (minute) = Set value) Example) 60 minutes = 60, 120 minutes = 120 by every 60 minutes
30076 to 39999	(Reserved Modbus register address)			

Unit No	Modbus register address	Function	Functional detail	Value
Indoor Unit	40001	(Reserved Modbus register address)		
	40002	Operation mode setting	Operation mode setting	0: No change 1: Auto 2: Cool 3: Dry 4: Heat 5: Fan
	40003	Operation ON/OFF setting	Operation ON/OFF setting	0: No change 1: Stop 2: Operation
	40004	Set temperature setting	Set temperature setting	bit0: Set temperature Change / No change (0: No change, 1: Change) bit1 to bit8: Set value (Temperature = Set value / 4) Example) 0°C = 0, 20°C = 80, 30°C = 120 by every 0.5°C

*1

*1 Explanation for temperature setting :

When set temperature is changed to 20°C;

Bit 0: 1

Bit 1~8: "Set temperature x 4" to convert binary

20 x 4 = 80 (decimal)

80 (decimal) → 0101 0000 (binary)

Put binary bit from 0 to 8

Value is "0 1010 0001" (binary), 161 (decimal)

When set temperature is not changed;

Bit 0: 0

Value is 0 (binary), (decimal)

Celsius	Fahrenheit	Value		
		Dec	Bin	Hex
18	64.4	145	1001 0001	91
19	66.2	153	1001 1001	99
20	68.0	161	1010 0001	A1
21	69.8	169	1010 1001	A9
22	71.6	177	1011 0001	B1
23	73.4	185	1011 1001	B9
24	75.2	193	1100 0001	C1
25	77.0	201	1100 1001	C9
26	78.8	209	1101 0001	D1
27	80.6	217	1101 1001	D9
28	82.4	225	1110 0001	E1
29	84.2	233	1110 1001	E9
30	86.0	241	1111 0001	F1

Unit No	Modbus register address	Function	Functional detail	Value
Indoor Unit	40005	Airflow setting	Airflow setting	0: No change 1: Auto 2: Quiet 3: Low 4: Med 5: High 6: Med-Low 7: Med-High
	40006	Vertical air direction position status	Vertical air direction position status monitoring	0: No change 1: Swing 2: Position 1 3: Position 2 4: Position 3 5: Position 4
	40007	Horizontal air direction position status	Horizontal air direction position status monitoring	0: No change 1: Swing 2: Position 1 3: Position 2 4: Position 3 5: Position 4 6: Position 5
	40008	Remote controller operation prohibition setting	Remote controller operation prohibition setting	bit0: Change / No change bit1: ALL operation settings (0: Not inhibit, 1: Valid) bit2: Timer setting (0: Not inhibit, 1: Valid) bit3: Room temperature setting (0: Not inhibit, 1: Valid) bit4: Operation mode setting (0: Not inhibit, 1: Valid) bit5: Start/Stop operation setting (0: Not inhibit, 1: Valid) bit6: Start operation setting (0: Not inhibit, 1: Valid) bit7: Filter Reset operation (0: Not inhibit, 1: Valid)
	40009	Filter sign reset	Filter sign reset	0: No change 1: Reset
	40010	Economy mode operation setting	Economy mode operation setting	0: No change 1: Normal operation 2: Save operation
	40011	Antifreeze operation setting	Antifreeze operation setting	0: No change 1: Release 2: Antifreeze operation

Unit No	Modbus register address	Function	Functional detail	Value	
Indoor Unit	40012	Temperature upper and lower limit Upper limit value setting (Cool/Dry)	Upper limit value setting for temperature upper and lower limit of Cool/Dry operation mode	bit0: Upper limit temperature Change / No change (0: No change, 1: Change) bit1 to bit8: 0: Invalid 1 to 255 : Set value (Temperature = Set value / 4) Example) 0.5°C = 2, 20°C = 80, 30°C =120 by every 0.5°C	*2
	40013	Temperature upper and lower limit Lower limit value setting (Cool/Dry)	Lower limit value setting for temperature upper and lower limit of Cool/Dry operation mode	bit0: Lower limit temperature Change / No change (0: No change, 1: Change) bit1 to bit8: 0: Invalid 1 to 255 : Set value (Temperature = Set value / 4) Example) 0.5°C = 2, 20°C = 80, 30°C =120 by every 0.5°C	*2
	40014	Temperature upper and lower limit Upper limit value setting (Heat)	Upper limit value setting for temperature upper and lower limit of Heat operation mode	bit0: Upper limit temperature Change / No change (0: No change, 1: Change) bit1 to bit8: 0: Invalid 1 to 255 : Set value (Temperature = Set value / 4) Example) 0.5°C = 2, 20°C = 80, 30°C =120 by every 0.5°C	*2
	40015	Temperature upper and lower limit Lower limit value setting (Heat)	Lower limit value setting for temperature upper and lower limit of Heat operation mode	bit0: Lower limit temperature Change / No change (0: No change, 1: Change) bit1 to bit8: 0: Invalid 1 to 255 : Set value (Temperature = Set value / 4) Example) 0.5°C = 2, 20°C = 80, 30°C =120 by every 0.5°C	*2
	40016	Temperature upper and lower limit: Upper limit value setting (Auto)	Upper limit value setting for temperature upper and lower limit of Auto operation mode	bit0: Upper limit temperature Change / No change (0: No change, 1: Change) bit1 to bit8: 0: Invalid 1 to 255 : Set value (Temperature = Set value / 4) Example) 0.5°C = 2, 20°C = 80, 30°C =120 by every 0.5°C	*2
	40017	Temperature upper and lower limit: Lower limit value setting (Auto)	Lower limit value setting for temperature upper and lower limit of Auto operation mode	bit0: Lower limit temperature Change / No change (0: No change, 1: Change) bit1 to bit8: 0: Invalid 1 to 255 : Set value (Temperature = Set value / 4) Example) 0.5°C = 2, 20°C = 80, 30°C =120 by every 0.5°C	*2

* Note

Set the temperature upper and lower limit setting (40012 to 40017) as follows.

- Set the set value so that "lower limit value" is smaller than "upper limit value".
- When switching between "No limit" and "Limit", always change all the limits (40012 to 40017) at the same time by using the function code (0x10).

*2: For setting details please refer to page 10

Unit No	Modbus register address	Function	Functional detail	Value
Indoor Unit	40018	External thermo-off setting	External thermo-off setting	0: No change 1: Release 2: Thermo-off
	40019	Human detection auto save setting	Human detection auto save setting	0: No change 1: No operation 2: Operation
	40020	Human detection auto save time setting	Human detection auto save set time setting	bit0: Change / No change (0: No change, 1: Change) bit1 to bit9: Time (minute) *(Time)/(1 minute) value is set Example) 60 minutes → 60, 120 minutes → 120 by every 15 minutes
	40021	Human detection auto off setting	Human detection auto offsetting	0: No change 1: No operation 2: Operation
	40022	Human detection auto off time status	Human detection auto off set time status monitoring	bit0: Change / No change (0: No change, 1: Change) bit1 to bit9: Set value (Time (minute) = Set value) Example) 60 minutes = 60, 120 minutes = 120 by every 60 minutes
	40023 to 49999	(Reserved Modbus register address)		